

福州飞华光电技术有限公司产品规格书

镜头参数 (Parameter of Lens)

型号 (Model) :	FH0824B-3MP				
	分辨率 (Resolution)	3 Megapixel			
	像面尺寸 (Image format)	1/2.7"			
	焦距 (Focal length)	8mm			
	通光孔径 (Aperture)	F2.4			
	接口 (Mount)	M12			
	视场角 (Field Angle) D×H×V(°)	1/2.7"	1/3	1/4	
		D	52.6	46.8	35.8
		H	42.1	37.4	28.6
	V	31.5	28.1	21.5	
	畸变 (Optical Distortion)	-15.00%	-11.80%	-6.20%	
	最近物距 (M. O. D.)	0.3m			
	外形尺寸 (Dimension)	Φ14×17.2mm			
	重量 (Weight)	5g			
	法兰后焦距 (Flange BFL)	/			
	光学后焦距 (BFL)	6.4mm			
机械后焦距 (MBF)	5.7mm				
日夜共焦 (IR Correction)	Yes				
操作方法 (Operation)	光圈 (Iris)	固定光圈 (FIX)			
	聚焦 (Focus)	/			
	变焦 (Zoom)	/			
工作温度 (Operating temperature)	-20℃~+60℃				

尺寸 (Size)

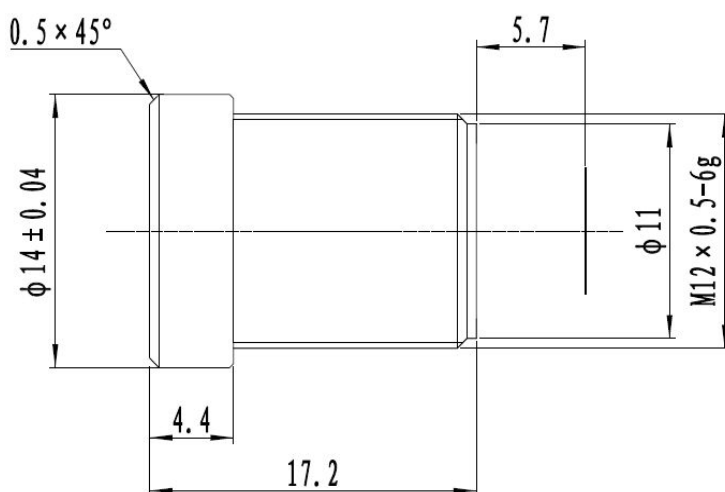

尺寸公差 Size tolerance (mm) :	0-10±0.05	10-30±0.10	30-120±0.20
角度公差 Angle tolerance	±2°		